

SECTION 10: PARTS

Table Saw Body Breakdown

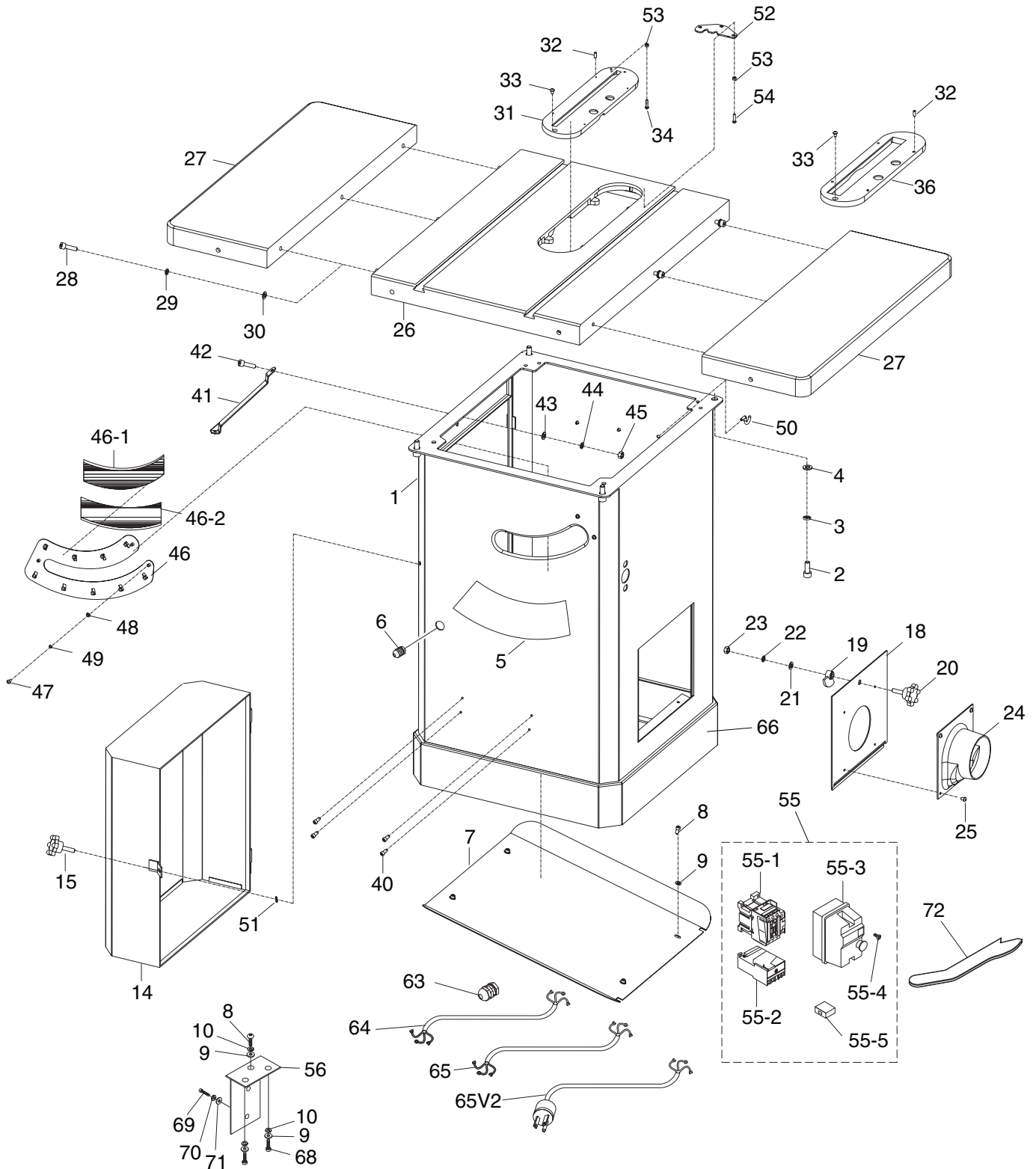

Table Saw Body Parts List

REF	PART #	DESCRIPTION
1	P0690001	CABINET
2	PSB88M	CAP SCREW M10-1.25 X 25
3	PLW06M	LOCK WASHER 10MM
4	PW04M	FLAT WASHER 10MM
5	P0690005	ANGLE SCALE
6	P0690006	STRAIN RELIEF
7	P0690007	CABINET PLATE
8	PS14M	PHLP HD SCR M6-1 X 12
9	PW03M	FLAT WASHER 6MM
10	PLW03M	LOCK WASHER 6MM
14	P0690014	MOTOR COVER
15	P0690015	KNOB M6-1
18	P0690018	CLEANOUT DOOR
19	P0690019	DOOR LATCH
20	P0690020	KNOB M8-1.25
21	PW01M	FLAT WASHER 8MM
22	PLW04M	LOCK WASHER 8MM
23	PN03M	HEX NUT M8-1.25
24	P0690024	DUST HOOD
25	PS05M	PHLP HD SCR M5-.8 X 8
26	P0690026	TABLE
27	P0690027	EXTENSION WING
28	PSB13M	CAP SCREW M8-1.25 X 30
29	PLW04M	LOCK WASHER 8MM
30	PW01M	FLAT WASHER 8MM
31	P0690031	STD TABLE INSERT
32	PSS53M	SET SCREW M5-.8 X 12
33	PS08M	PHLP HD SCR M5-.8 X 12
34	PS06M	PHLP HD SCR M5-.8 X 20
36	P0690036	DADO TABLE INSERT
40	P0690040	NAME PLATE RIVET
41	P0690041	SHIPPING BRACE

REF	PART #	DESCRIPTION
42	PB74M	HEX BOLT M10-1.5 X 20
43	PW04M	FLAT WASHER 10MM
44	PLW06M	LOCK WASHER 10MM
45	PN02M	HEX NUT M10-1.5
46	P0690046	DUST CLIP
46-1	P0690046-1	UPPER BRUSH
46-2	P0690046-2	LOWER BRUSH
47	PS02M	PHLP HD SCR M4-.7 X 12
48	PW05M	FLAT WASHER 4MM
49	PLW02M	LOCK WASHER 4MM
50	P0690050	HOOK
51	PTLW13M	INT TOOTH WASHER 6MM
52	P0690052	LIMIT PLATE
53	PN06M	HEX NUT M5-.8
54	PS06M	PHLP HD SCR M5-.8 X 20
55	P0690055	MAG SWITCH ASSEMBLY MS-15
55-1	P0690055-1	CONTACTOR CHINT NC1-18
55-2	P0690055-2	OL RELAY CHINT NR2-25 12~18
55-3	P0690055-3	SWITCH BOX FRONT/BACK
55-4	P0690055-4	MAG SWITCH COVER SCREW
55-5	P0690055-5	ON/OFF SWITCH CHINT NP2
56	P0690056	SWITCH BRACKET
63	P0690063	STRAIN RELIEF
64	P0690064	MOTOR CORD 14AWG X 3C
65	P0690065	POWER CORD V1.01.09
65V2	P0690065V2	POWER CORD W/PLUG V2.12.09
66	P0690066	GREEN TRIM TAPE
68	PB02M	HEX BOLT M6-1 X 12
69	PBHS09M	BUTTON HD CAP SCR M5-.8 X 16
70	PLW01M	LOCK WASHER 5MM
71	PW02M	FLAT WASHER 5MM
72	P0690072	PUSH STICK



Trunnion Assembly Breakdown

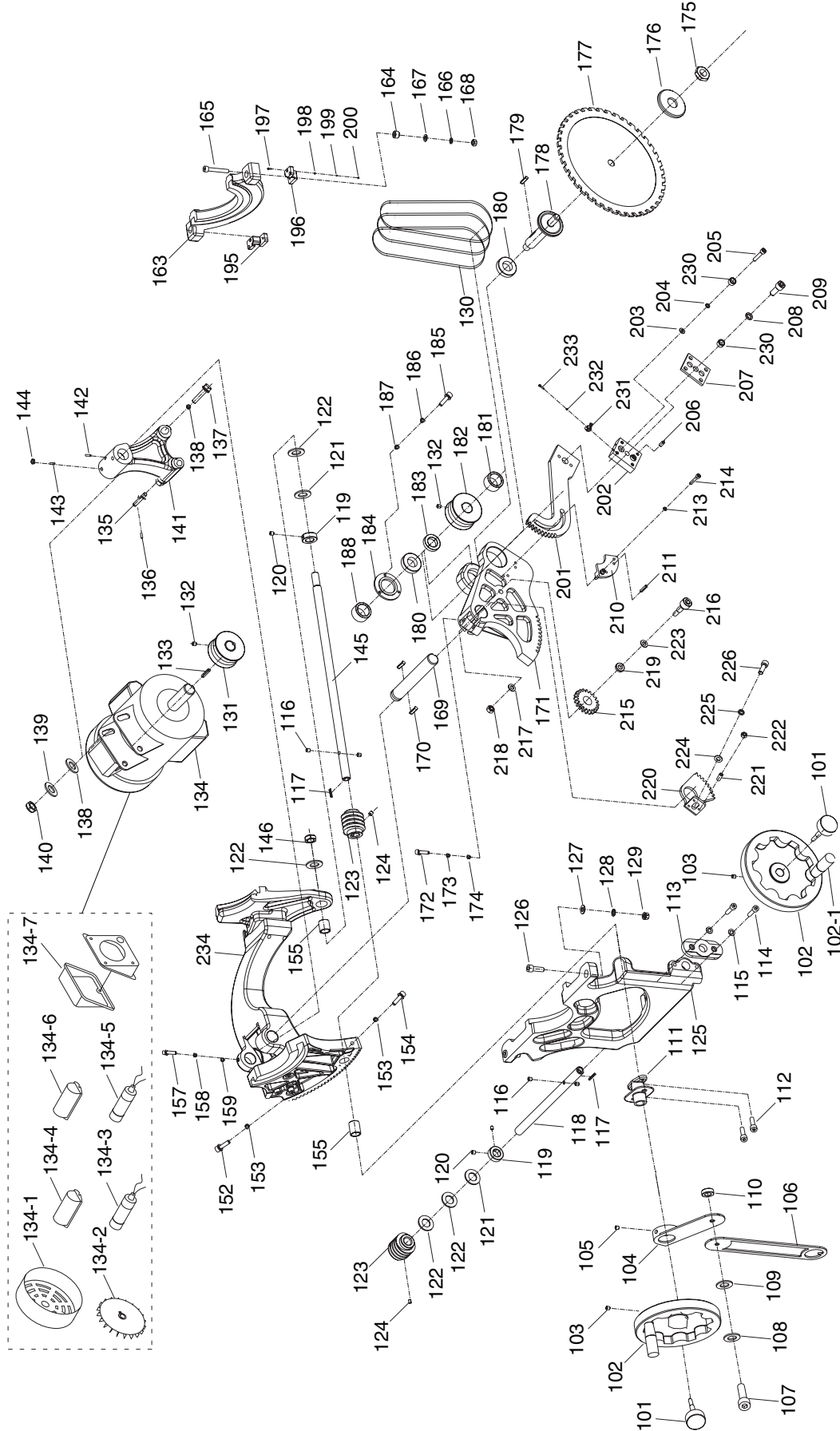

Trunnion Assembly Parts List

REF	PART #	DESCRIPTION
101	P0690101	HANDWHEEL LOCK
102-1	P0690102-1	HANDWHEEL HANDLE
102	P0690102	HANDWHEEL
103	PSS53M	SET SCREW M5-.8 X 12
104	P0690104	ANGLE POINTER-1
105	PSS26M	SET SCREW M5-.8 X 6
106	P0690106	ANGLE POINTER-2
107	PSB26M	CAP SCREW M6-1 X 12
108	PLW03M	LOCK WASHER 6MM
109	PW03M	FLAT WASHER 6MM
110	PN01M	HEX NUT M6-1
111	P0690111	ANGLE POINTER BRACKET
112	PSB38M	CAP SCREW M5-.8 X 25
113	P0690113	PLATE
114	PSB31M	CAP SCREW M8-1.25 X 25
115	PLW04M	LOCK WASHER 8MM
116	P0690116	PIN-LOCK-SHAFT
117	PK170M	KEY 5 X 5 X 36
118	P0690118	ANGLE SHAFT
119	P0690119	LOCK COLLAR
120	PSS03M	SET SCREW M6-1 X 8
121	PLW12M	LOCK WASHER 18MM
122	P0690122	COPPER WASHER 18MM
123	P0690123	WORM
124	PSS01M	SET SCREW M6-1 X 10
125	P0690125	FRONT TRUNNION
126	PSB72M	CAP SCREW M10-1.5 X 30
127	PW04M	FLAT WASHER 10MM
128	PLW06M	LOCK WASHER 10MM
129	PN02M	HEX NUT M10-1.5
130	P0690130	BELT SPZ 625
131	P0690131	MOTOR PULLEY
132	PSS53M	SET SCREW M5-.8 X 12
133	PK12M	KEY 5 X 5 X 30
134	P0690134	MOTOR 3HP 220V 1-PH
134-1	P0690134-1	FAN COVER
134-2	P0690134-2	MOTOR FAN
134-3	P0690134-3	R CAP 25M 370V 1-3/4 X 3
134-4	P0690134-4	R CAPACITOR COVER
134-5	P0690134-5	S CAP 200M 250V 1-1/4 X 2-3/4
134-6	P0690134-6	S CAPACITOR COVER
134-7	P0690134-7	WIRING JUNCTION BOX
135	P0690135	ORIENTATION PIN
136	P0690136	ROLL PIN 4 X 28
137	PB121M	HEX BOLT M12-1.75 X 100
138	PW06M	FLAT WASHER 12MM

REF	PART #	DESCRIPTION
139	PLW05M	LOCK WASHER 12MM
140	PN09M	HEX NUT M12-1.75
141	P0690141	MOTOR FRAME SUPPORT
142	PSS14M	SET SCREW M8-1.25 X 12
143	PSS19M	SET SCREW M8-1.25 X 30
144	PN03M	HEX NUT M8-1.25
145	P0690145	HIGH SHAFT
146	PLN14M	LOCK NUT M18-1.5
152	PB09M	HEX BOLT M8-1.25 X 20
153	PN03M	HEX NUT M8-1.25
154	PB20M	HEX BOLT M8-1.25 X 35
155	P0690155	FLANGE CASTING SLEEVE
157	PSS20M	SET SCREW M8-1.25 X 8
158	P0690158	COMPRESSION SPRING
159	P0690159	BALL
163	P0690163	REAR TRUNNION
164	P0690164	ADJUST BOLT
165	PSB13M	CAP SCREW M8-1.25 X 30
166	PW01M	FLAT WASHER 8MM
167	PLW04M	LOCK WASHER 8MM
168	PN03M	HEX NUT M8-1.25
169	P0690169	HIGH SHAFT
170	PK44M	KEY 6 X 6 X 50
171	P0690171	GEARED BEARING HOUSING
172	PB116M	HEX BOLT M10-1.5 X 45
173	PLW06M	LOCK WASHER 10MM
174	PW04M	FLAT WASHER 10MM
175	P0690175	ARBOR NUT
176	P0690176	ARBOR FLANGE
177	P0690177	BLADE 10" 40T
178	P0690178	BLADE ARBOR
179	PK12M	KEY 5 X 5 X 30
180	P6005	BALL BEARING 6005 ZZ
181	P0690181	COLLAR BLADE ARBOR
182	P0690182	ARBOR PULLEY
183	P0690183	COLLAR BLADE ARBOR
184	P0690184	FLANGE RING
185	PS08M	PHLP HD SCR M5-.8 X 12
186	PLW01M	LOCK WASHER 5MM
187	PW02M	FLAT WASHER 5MM
188	P0690188	LOCK NUT M16-1.5
195	P0690195	LEFT BRACKET
196	P0690196	RIGHT BRACKET
197	PSB13M	CAP SCREW M8-1.25 X 30
198	PW01M	FLAT WASHER 8MM
199	PLW04M	LOCK WASHER 8MM



REF	PART #	DESCRIPTION
200	PN03M	HEX NUT M8-1.25
201	P0690201	BULL GEAR
202	P0690202	SPLITTER ADJUST BLOCK
203	PW03M	FLAT WASHER 6MM
204	PLW03M	LOCK WASHER 6MM
205	PSB06M	CAP SCREW M6-1 X 25
206	PSS04M	SET SCREW M6-1 X 12
207	P0690207	SPLITTER TIGHTEN CLIP
208	PLW03M	LOCK WASHER 6MM
209	PB08M	HEX BOLT M6-1 X 20
210	P0690210	ORIENTATION BAR
211	PRP49M	ROLL PIN 5 X 25
213	PLW01M	LOCK WASHER 5MM
214	PSB38M	CAP SCREW M5-.8 X 25
215	P0690215	GEAR
216	PSB47M	CAP SCREW M10-1.5 X 40

REF	PART #	DESCRIPTION
217	PW04M	FLAT WASHER 10MM
218	PLN05M	LOCK NUT M10-1.5
219	P0690219	GEAR SLEEVE
220	P0690220	PLATE GEAR
221	PSS25M	SET SCREW M6-1 X 20
222	PN01M	HEX NUT M6-1
223	PWF10M	FENDER WASHER 10MM
224	PW01M	FLAT WASHER 8MM
225	PLW04M	LOCK WASHER 8MM
226	PSB14M	CAP SCREW M8-1.25 X 20
230	P0690230	SPACER
231	P0690231	POSITION PIN SET
232	PLW02M	LOCK WASHER 4MM
233	PSS22M	SET SCREW M4-.7 X 12
234	P0690234	TRUNNION



Blade Guard Breakdown

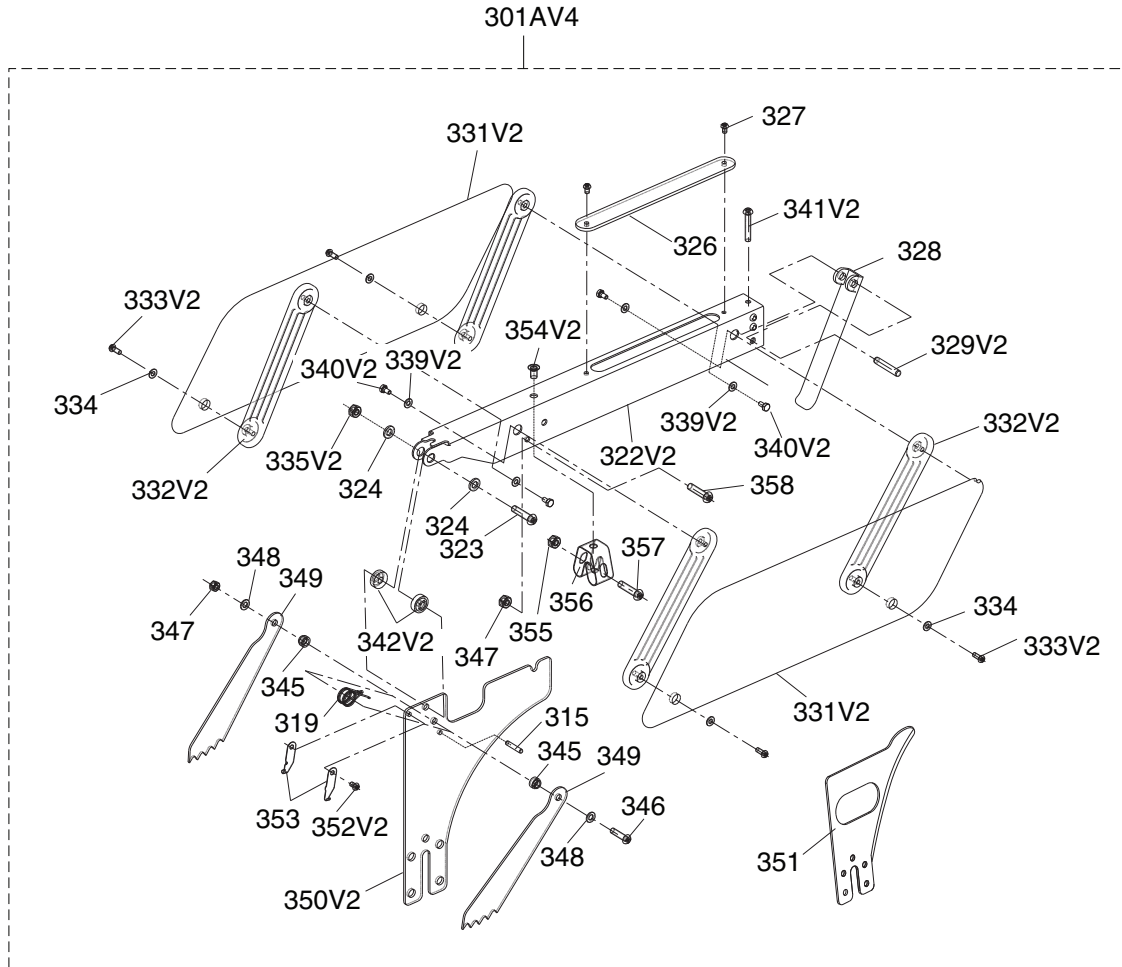

REF	PART #	DESCRIPTION
301AV4	P0690301AV4	BLADE GUARD ASSEMBLY V4.11.10
315	PRP39M	ROLL PIN 4 X 20
319	P0690319	TORSION SPRING
322V2	P0690322V2	SUPPORTING ARM V2.10.10
323	PS47M	PHLP HD SCR M6-1 X 25
324	PW03M	FLAT WASHER 6MM
326	P0690326	TOP GUARD
327	PS17M	PHLP HD SCR M4-.7 X 6
328	P0690328	FRONT GUARD
329V2	PRP107M	ROLL PIN 6 X 32
331V2	P0690331V2	SIDE GUARD V2.10.10
332V2	P0690332V2	GUARD SUPPORT V2.10.10
333V2	PS38M	PHLP HD SCR M4-.7 X 10
334	PW02M	FLAT WASHER 5MM
335V2	PLN03M	LOCK NUT M6-1
339V2	PW02M	FLAT WASHER 5MM
340V2	PB122M	HEX BOLT M4-.7 X 8

REF	PART #	DESCRIPTION
341V2	PS62M	PHLP HD SCR M6-1 X 30
342V2	P0690342V2	SPACER V2.10.10
345	P0690345	SPACER
346	PB42M	HEX BOLT M5-.8 X 20
347	PLN02M	LOCK NUT M5-.8
348	PW02M	FLAT WASHER 5MM
349	P0690349	PAWL
350V2	P0690350V2	SPLITTER V2.12.09
351	P0690351	RIVING KNIFE
352V2	P0690352V2	RIVET V2.11.10
353	P0690353	RIVING KNIFE HOOK PLATE
354V2	P0690354V2	RIVET 5 X 12MM V2.11.10
355	PLN03M	LOCK NUT M6-1
356	P0690356	GUARD CLAMP
357	PS31M	PHLP HD SCR M6-1 X 35
358	PB11M	HEX BOLT M5-.8 X 8



Miter Gauge Breakdown

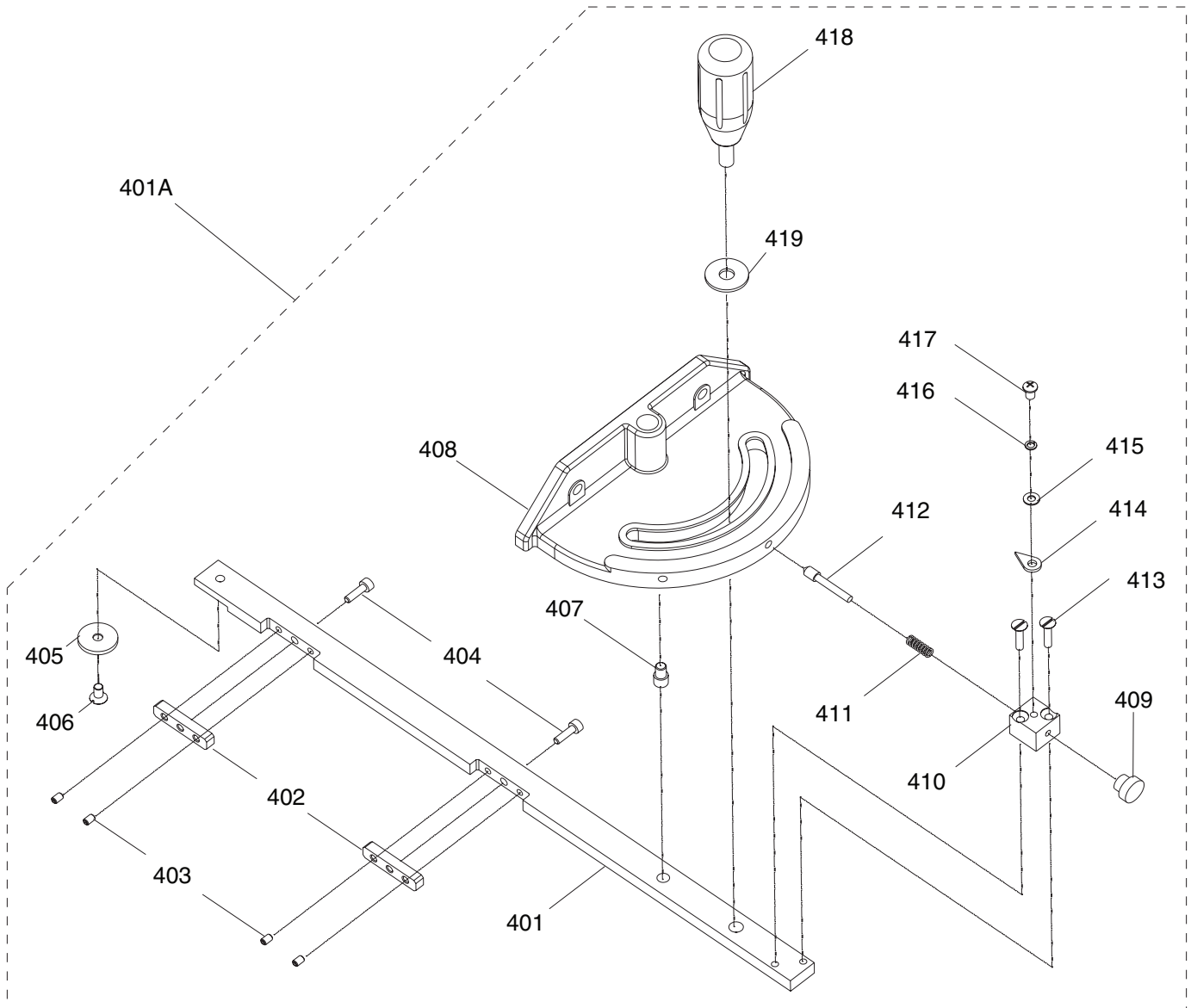

REF	PART #	DESCRIPTION
401A	P0690401A	MITER GAUGE ASSEMBLY
401	P0690401	MITER BAR
402	P0690402	GIB
403	PSS79M	SET SCREW M4-.7 X 6
404	PSB41M	CAP SCREW M4-.7 X 14
405	P0690405	MITER RING
406	PFH30M	FLAT HD SCR M5-.8 X 8
407	P0690407	MITER BODY PIVOT PIN
408	P0690408	MITER GAUGE BODY
409	P0690409	MITER STOP PIN KNOB

REF	PART #	DESCRIPTION
410	P0690410	MITER STOP PIN BLOCK
411	P0690411	COMPRESSION SPRING
412	P0690412	MITER STOP PIN
413	PFH77M	FLAT HD SCR M4-.7 X 20
414	P0690414	POINTER MITER GAUGE
415	PW05M	FLAT WASHER 4MM
416	PLW02M	LOCK WASHER 4MM
417	PS07M	PHLP HD SCR M4-.7 X 8
418	P0690418	MITER KNOB
419	PWF08M	FENDER WASHER 8MM



Fence

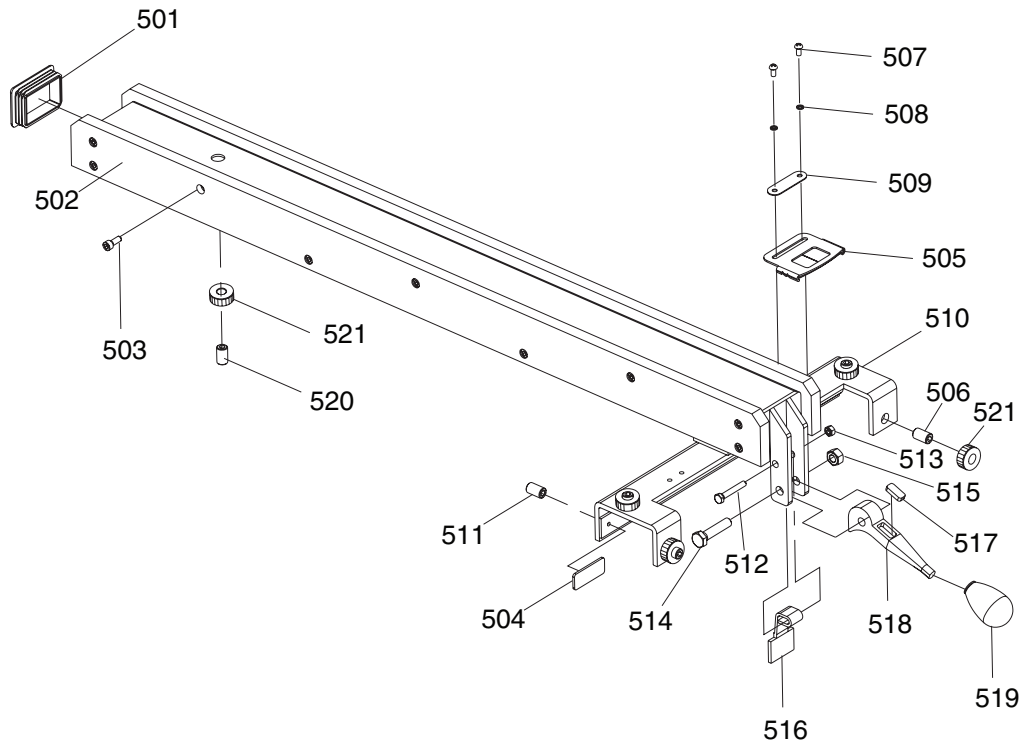

REF	PART #	DESCRIPTION
501	P0690501	FENCE INSERT
502	P0690502	FENCE FACE
503	P0690503	CAP SCREW M6-1 X 16
504	P0690504	GLIDE PAD
505	P0690505	FENCE SCALE WINDOW
506	P0690506	SET SCREW M12-1.75 X 15
507	P0690507	PHLP HD SCR M5-.8 X 10
508	P0690508	LOCK WASHER 5MM
509	P0690509	INDICATOR
510	P0690510	FENCE BODY
511	P0690511	SET SCREW

REF	PART #	DESCRIPTION
512	P0690512	HEX BOLT M6-1 X 40
513	P0690513	LOCK NUT M6-1
514	P0690514	HEX BOLT M10-1.5 X 45
515	P0690515	LOCK NUT M10-1.25
516	P0690516	CAM FOOT
517	P0690517	MAGNET
518	P0690518	CAM
519	P0690519	FENCE LOCK KNOB
520	P0690520	BRASS GLIDE SCREW M12-1.75 X 30
521	P0690521	SPECIAL LOCKING NUT M12-1.75



Model G0690 Extension Table Breakdown

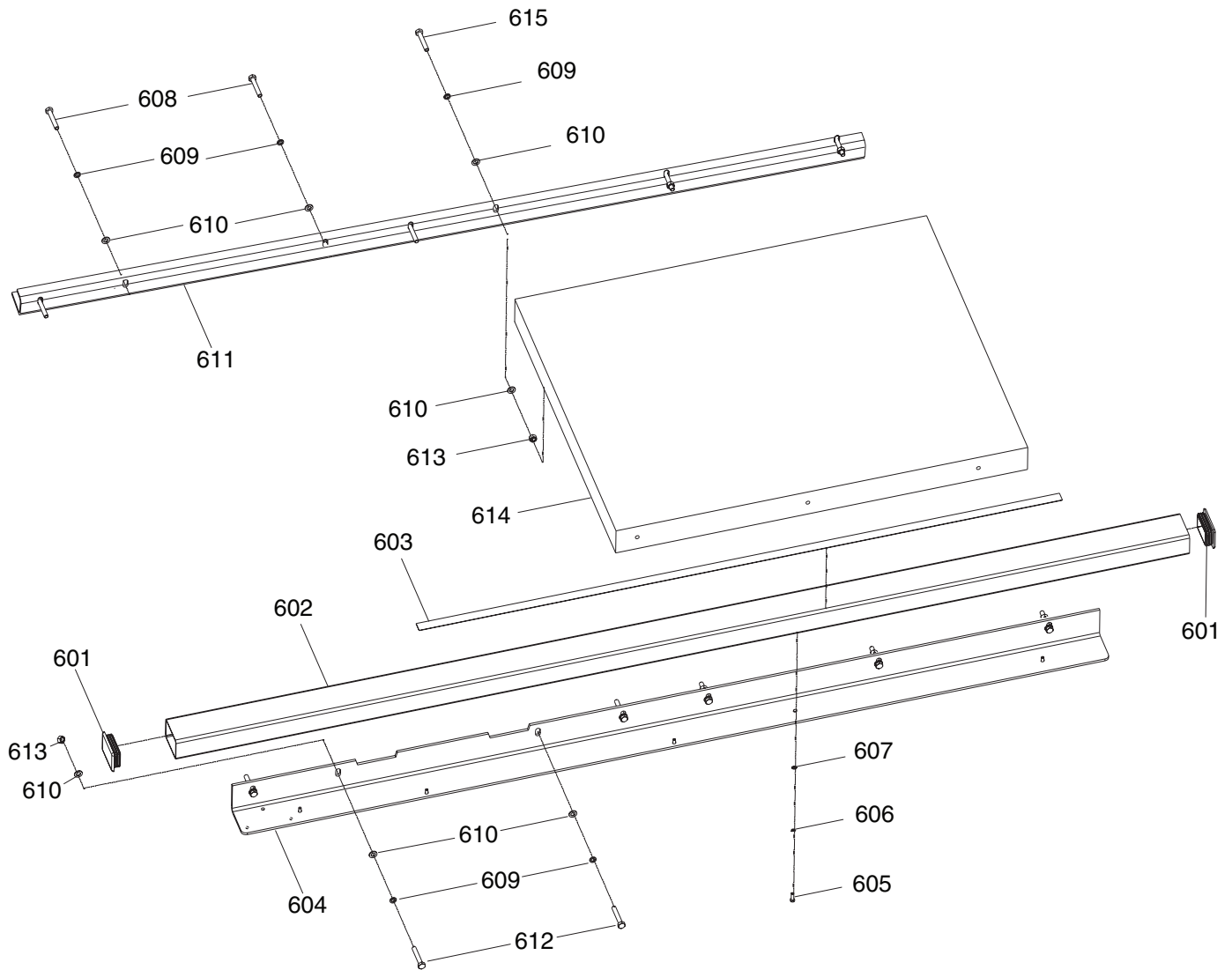

REF	PART #	DESCRIPTION
601	P0690601	FENCE INSERT
602	P0690602	GUIDE TUBE
603	P0690603	SCALE
604	P0690604	FRONT RAIL
605	PSB01M	CAP SCREW M6-1 X 16
606	PLW03M	LOCK WASHER 6MM
607	PW03M	FLAT WASHER 6MM
608	PB11	HEX BOLT 5/16-18 X 1-1/2

REF	PART #	DESCRIPTION
609	PLW04M	LOCK WASHER 8MM
610	PW01M	FLAT WASHER 8MM
611	P0690611	REAR RAIL
612	PB126M	HEX BOLT M8-1.25 X 40
613	PN03M	HEX NUT M8-1.25
614	P0690614	TABLE BOARD
615	PB26M	HEX BOLT M8-1.25 X 30



Model G0691 Extension Table Breakdown

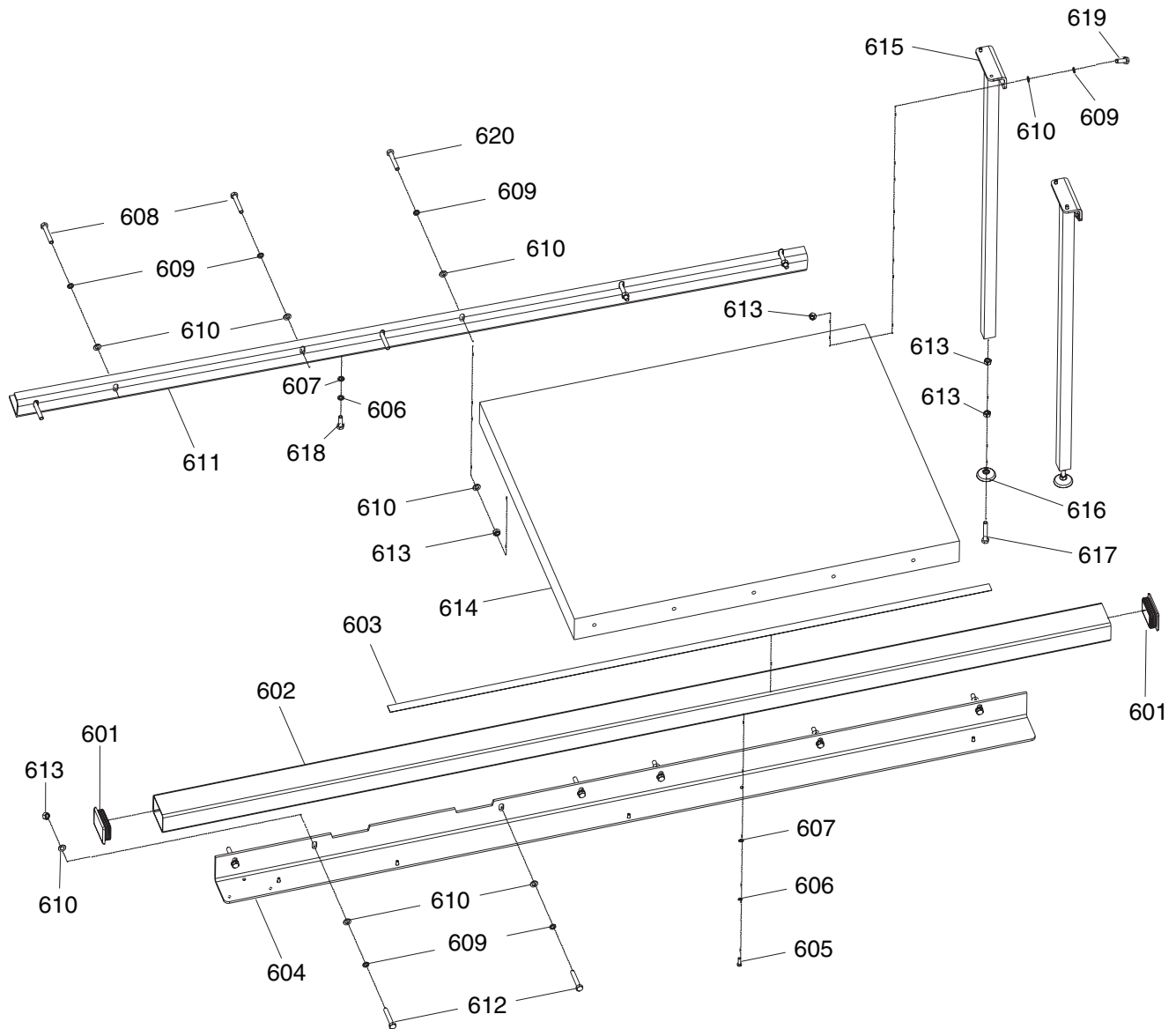

REF	PART #	DESCRIPTION
601	P0691601	FENCE INSERT
602	P0691602	GUIDE TUBE
603	P0691603	SCALE
604	P0691604	FRONT RAIL
605	PSB01M	CAP SCREW M6-1 X 16
606	PLW03M	LOCK WASHER 6MM
607	PW03M	FLAT WASHER 6MM
608	PB11	HEX BOLT 5/16-18 X 1-1/2
609	PLW04M	LOCK WASHER 8MM
610	PW01M	FLAT WASHER 8MM

REF	PART #	DESCRIPTION
611	P0691611	REAR RAIL
612	PB126M	HEX BOLT M8-1.25 X 40
613	PN03M	HEX NUT M8-1.25
614	P0691614	TABLE BOARD
615	P0691615	LEG
616	P0691616	FOOT
617	PB28M	HEX BOLT M8-1.25 X 60
618	PSB01M	CAP SCREW M6-1 X 16
619	PSB14M	CAP SCREW M8-1.25 X 20
620	PB26M	HEX BOLT M8-1.25 X 30



Labels and Cosmetic Parts Breakdown

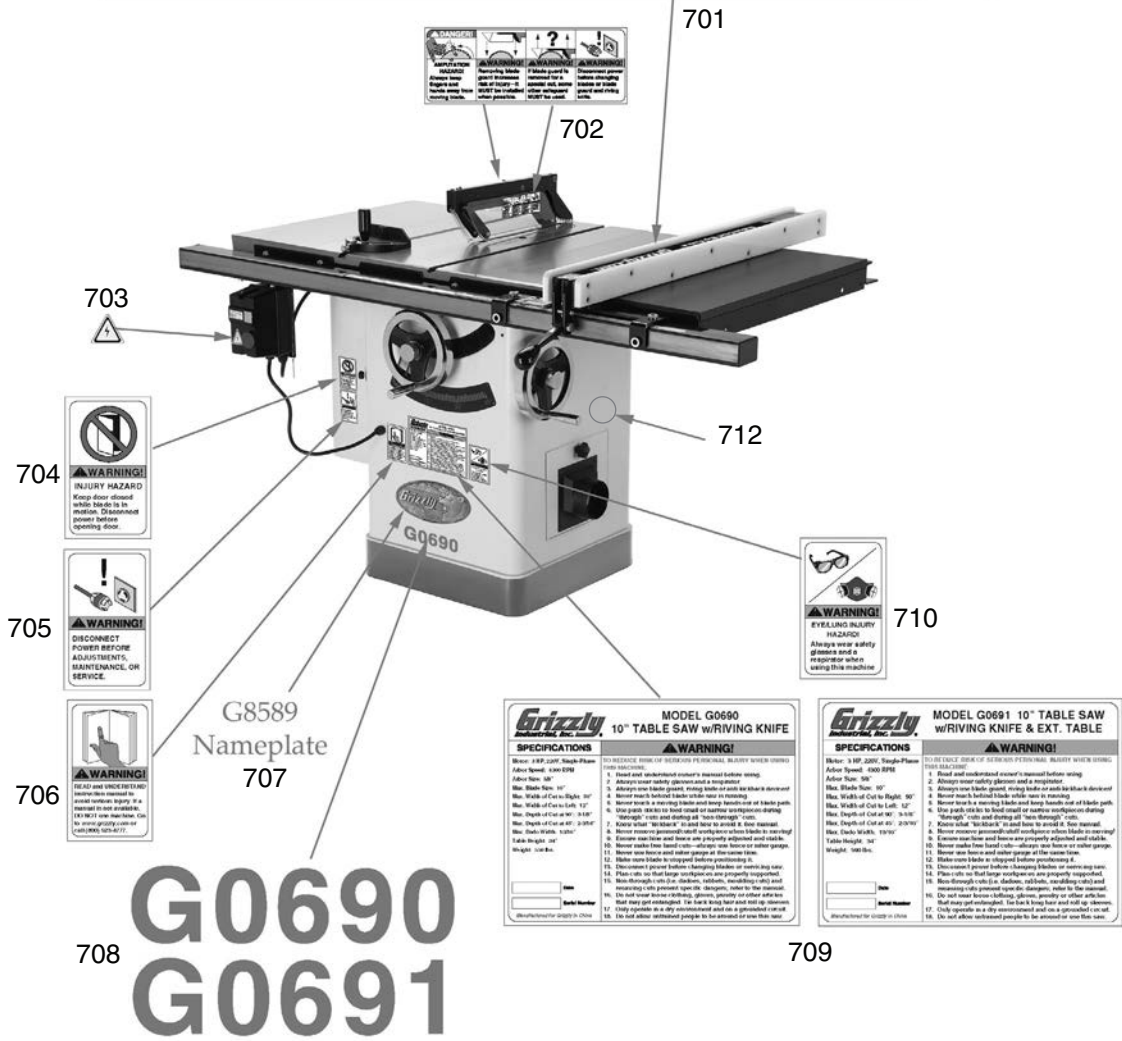

REF	PART #	DESCRIPTION
701	P0690701	FENCE LABEL
702	P0690702	GUARD LABEL
703	PLABEL-14	ELECTRICITY LABEL
704	P0690704	KEEP CLOSED LABEL
705	PLABEL-63	UNPLUG POWER LABEL
706	PLABEL-12A	READ MANUAL LABEL
707	G8589	GRIZZLY NAMEPLATE

REF	PART #	DESCRIPTION
708	P0690708	MODEL # LABEL G0690
708	P0691708	MODEL # LABEL G0691
709	P0690709	MACHINE ID LABEL G0690
709	P0691709	MACHINE ID LABEL G0691
710	PLABEL-43	GLASSES RESPIRATOR LABEL
712	PPAINT-11	"PUTTY" PAINT

⚠ WARNING

Safety labels warn about machine hazards and ways to prevent injury. The owner of this machine **MUST** maintain the original location and readability of the labels on the machine. If any label is removed or becomes unreadable, **REPLACE** that label before using the machine again. Contact Grizzly at (800) 523-4777 or www.grizzly.com to order new labels.

